

UNR911xG Series

Silicon PNP epitaxial planar type

For digital circuits

■ Features

- Costs can be reduced through downsizing of the equipment and reduction of the number of parts.
- SS-Mini type package, allowing automatic insertion through tape packing.

■ Resistance by Part Number

	Marking Symbol	(R ₁)	(R ₂)
• UNR9110G	6L	47 kΩ	—
• UNR9111G	6A	10 kΩ	10 kΩ
• UNR9112G	6B	22 kΩ	22 kΩ
• UNR9113G	6C	47 kΩ	47 kΩ
• UNR9114G	6D	10 kΩ	47 kΩ
• UNR9115G	6E	10 kΩ	—
• UNR9116G	6F	4.7 kΩ	—
• UNR9117G	6H	22 kΩ	—
• UNR9118G	6I	0.51 kΩ	5.1 kΩ
• UNR9119G	6K	1 kΩ	10 kΩ
• UNR911AG	6X	100 kΩ	100 kΩ
• UNR911BG	6Y	100 kΩ	—
• UNR911CG	6Z	—	47 kΩ
• UNR911DG	6M	47 kΩ	10 kΩ
• UNR911EG	6N	47 kΩ	22 kΩ
• UNR911FG	6O	4.7 kΩ	10 kΩ
• UNR911HG	6P	2.2 kΩ	10 kΩ
• UNR911LG	6Q	4.7 kΩ	4.7 kΩ
• UNR911MG	EI	2.2 kΩ	47 kΩ
• UNR911NG	EW	4.7 kΩ	47 kΩ
• UNR911TG	EY	22 kΩ	47 kΩ
• UNR911VG	FC	2.2 kΩ	2.2 kΩ

■ Package

- Code
SSMini3-F3
- Pin Name
1: Base
2: Emitter
3: Collector

■ Internal Connection

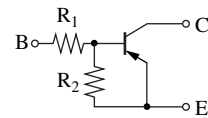

■ Absolute Maximum Ratings T_a = 25°C

Parameter	Symbol	Rating	Unit
Collector-base voltage (Emitter open)	V _{CBO}	-50	V
Collector-emitter voltage (Base open)	V _{CEO}	-50	V
Collector current	I _C	-100	mA
Total power dissipation	P _T	125	mW
Junction temperature	T _j	125	°C
Storage temperature	T _{stg}	-55 to +125	°C

■ Electrical Characteristics $T_a = 25^\circ\text{C} \pm 3^\circ\text{C}$

Parameter		Symbol	Conditions	Min	Typ	Max	Unit
Collector-base voltage (Emitter open)		V_{CBO}	$I_C = -10 \mu\text{A}, I_E = 0$	-50			V
Collector-emitter voltage (Base open)		V_{CEO}	$I_C = -2 \text{mA}, I_B = 0$	-50			V
Collector-base cutoff current (Emitter open)		I_{CBO}	$V_{CB} = -50 \text{V}, I_E = 0$			-0.1	μA
Collector-base cutoff current (Emitter open)		I_{CEO}	$V_{CE} = -50 \text{V}, I_B = 0$			-0.5	μA
Emitter-base cutoff current (Collector open)	UNR9110G/9115G/ 9116G/9117G/911BG	I_{EBO}	$V_{EB} = -6 \text{V}, I_C = 0$			-0.01	mA
	UNR9113G/911AG					-0.1	
	UNR9112G/9114G/911DG/ 911EG/911MG/911NG/911TG					-0.2	
	UNR9111G					-0.5	
	UNR911FG/911HG					-1.0	
	UNR9119G					-1.5	
	UNR9118G/911CG/911LG/911VG					-2.0	
	Forward current transfer ratio			UNR911VG	h_{FE}	$V_{CE} = -10 \text{V}, I_C = -5 \text{mA}$	
UNR9118G/911LG		20					
UNR9119G/911DG/911FG/911HG		30					
UNR9111G		35					
UNR9112G/911EG		60					
UNR9113G/9114G/ 911AG/911CG/911MG		80					
UNR911NG/911TG		80		400			
UNR9110G/9115G/ 9116G/9117G/911BG		160		460			
Collector-emitter saturation voltage		$V_{CE(sat)}$	$I_C = -10 \text{mA}, I_B = -0.3 \text{mA}$			-0.25	V
	UNR911VG		$I_C = -10 \text{mA}, I_B = -1.5 \text{mA}$				
Output voltage high-level		V_{OH}	$V_{CC} = -5 \text{V}, V_B = -0.5 \text{V}, R_L = 1 \text{k}\Omega$	-4.9			V
Output voltage low-level		V_{OL}	$V_{CC} = -5 \text{V}, V_B = -2.5 \text{V}, R_L = 1 \text{k}\Omega$			-0.2	V
			$V_{CC} = -5 \text{V}, V_B = -3.5 \text{V}, R_L = 1 \text{k}\Omega$				
			$V_{CC} = -5 \text{V}, V_B = -10 \text{V}, R_L = 1 \text{k}\Omega$				
			$V_{CC} = -5 \text{V}, V_B = -6 \text{V}, R_L = 1 \text{k}\Omega$				
			$V_{CC} = -5 \text{V}, V_B = -5 \text{V}, R_L = 1 \text{k}\Omega$				
Transition frequency		f_T	$V_{CB} = -10 \text{V}, I_E = 1 \text{mA}, f = 200 \text{MHz}$		80		MHz
	UNR9113G		$V_{CB} = -10 \text{V}, I_E = 1 \text{mA}, f = 200 \text{MHz}$		150		
	UNR911AG		$V_{CB} = -10 \text{V}, I_E = 2 \text{mA}, f = 200 \text{MHz}$		80		
	UNR911CG		$V_{CB} = -10 \text{V}, I_E = 2 \text{mA}, f = 200 \text{MHz}$		150		
Input resistance	UNR9118G	R_i		-30%	0.51	+30%	k Ω
	UNR9119G				1.0		
	UNR911HG/911MG/911VG				2.2		
	UNR9116G/911FG/911LG/911NG				4.7		
	UNR9111G/9114G/9115G				10		
	UNR9112G/9117G/911TG				22		
	UNR9110G/9113G/911DG/911EG				47		
	UNR911AG/911BG				100		

■ Electrical Characteristics (continued) $T_a = 25^\circ\text{C} \pm 3^\circ\text{C}$

Parameter		Symbol	Conditions	Min	Typ	Max	Unit
Emitter-base resistance	UNR911CG	R_2		-30%	47	+30%	k Ω
Resistance ratio	UNR911MG	R_1/R_2			0.047		—
	UNR911NG				0.1		
	UNR9118G/9119G			0.08	0.10	0.12	
	UNR9114G			0.17	0.21	0.25	
	UNR911HG			0.17	0.22	0.27	
	UNR911TG				0.47		
	UNR911FG			0.37	0.47	0.57	
	UNR911AG/911VG				1.0		
	UNR9111G/9112G/9113G/911LG			0.8	1.0	1.2	
	UNR911EG			1.70	2.14	2.60	
	UNR911DG			3.7	4.7	5.7	

Note) Measuring methods are based on JAPANESE INDUSTRIAL STANDARD JIS C 7030 measuring methods for transistors.

Common characteristics chart

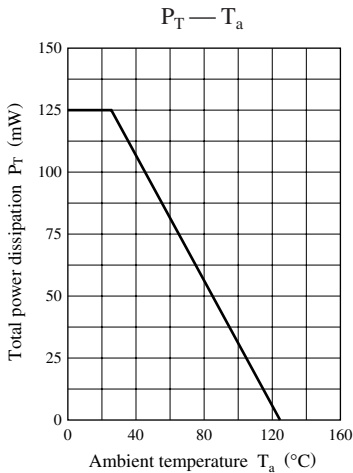

Characteristics charts of UNR9110G

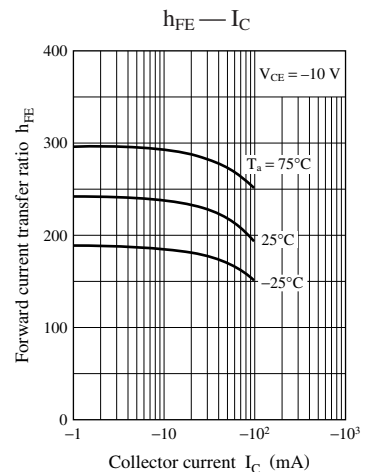
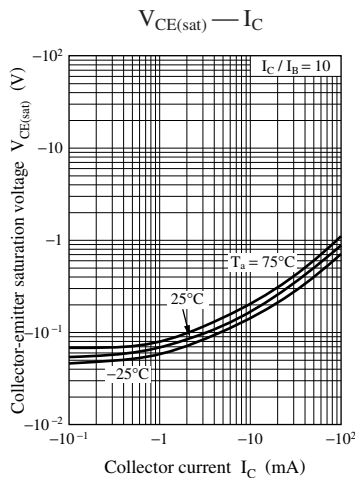
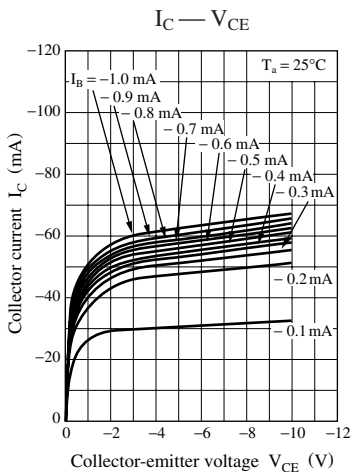

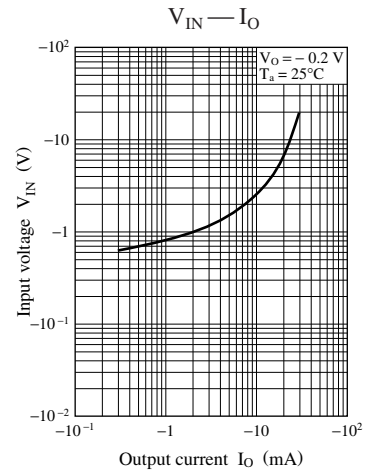
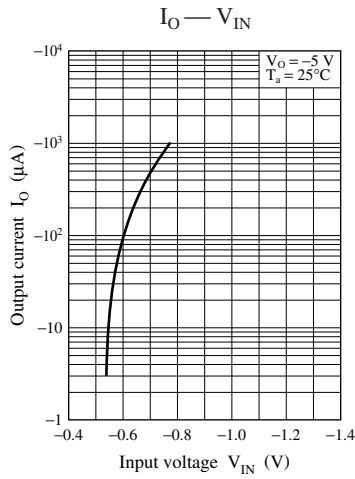
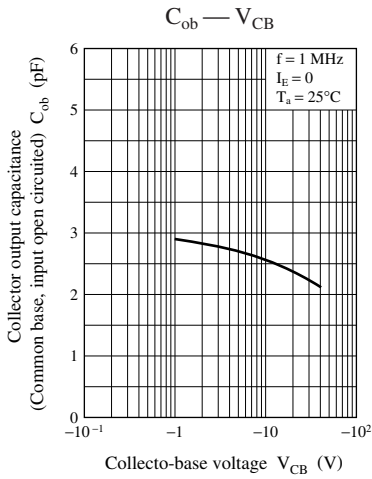

Characteristics charts of UNR9111G

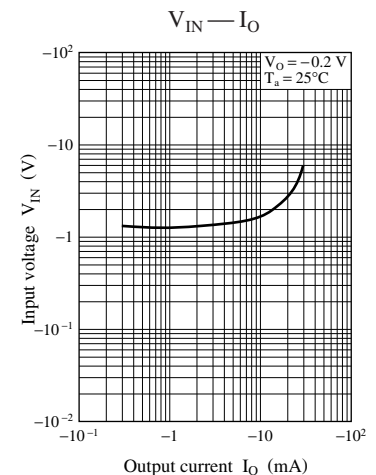
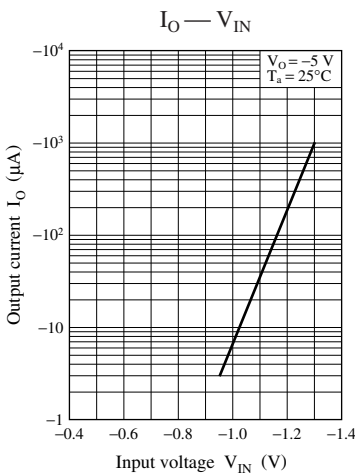
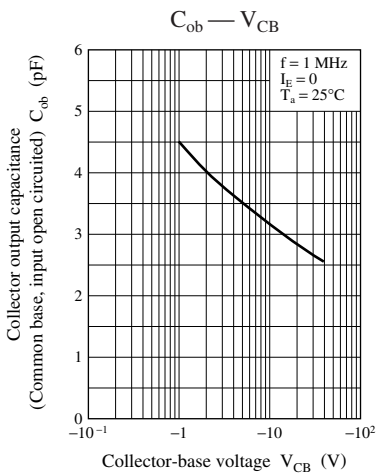
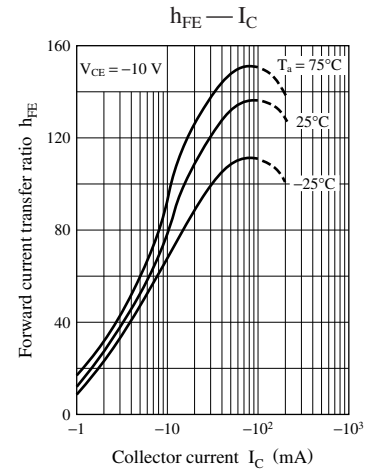
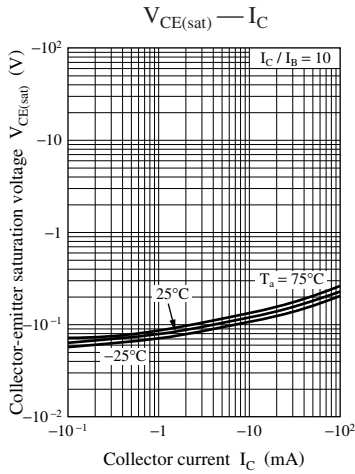
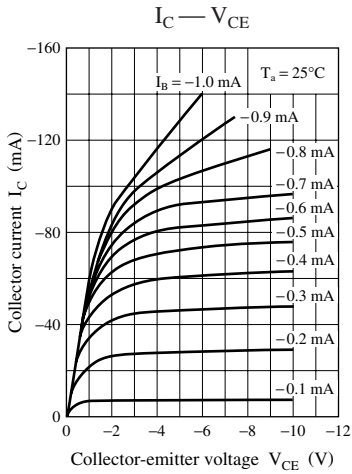

Characteristics charts of UNR9112G

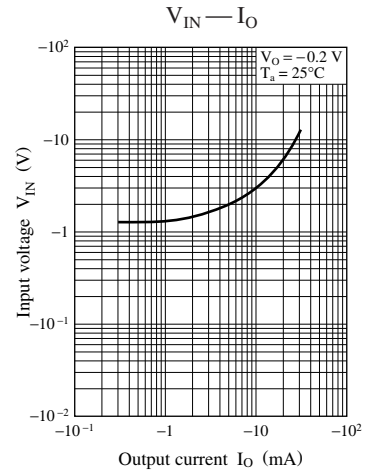
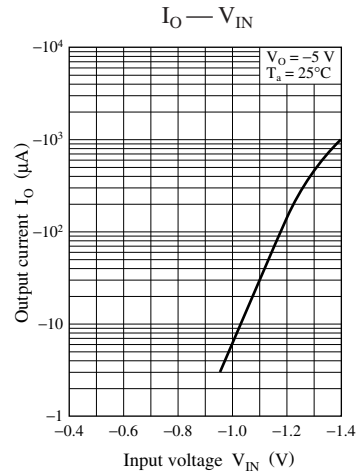
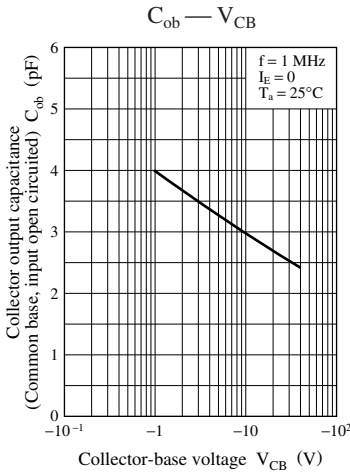
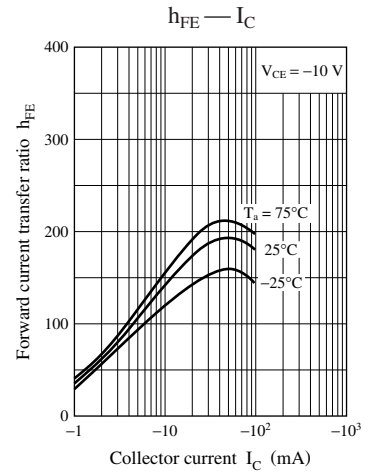
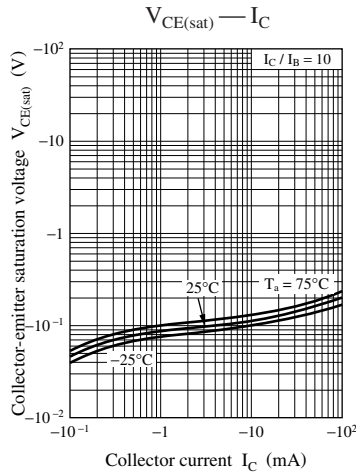
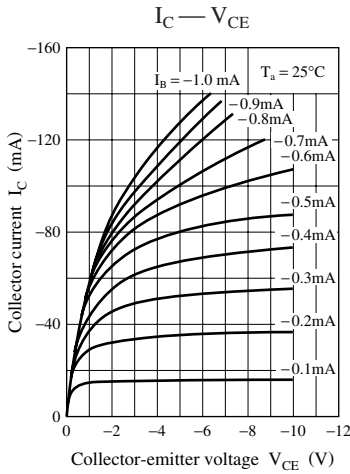

Characteristics charts of UNR9113G

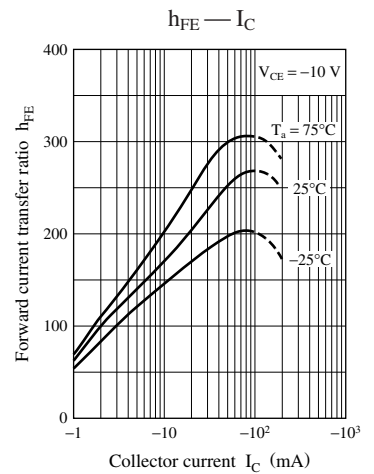
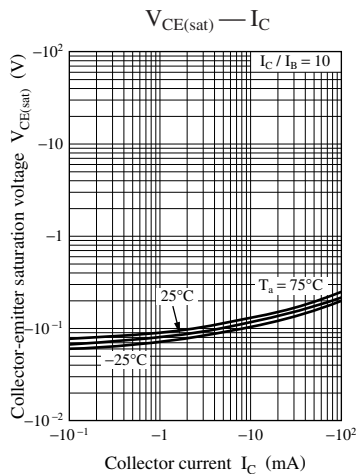
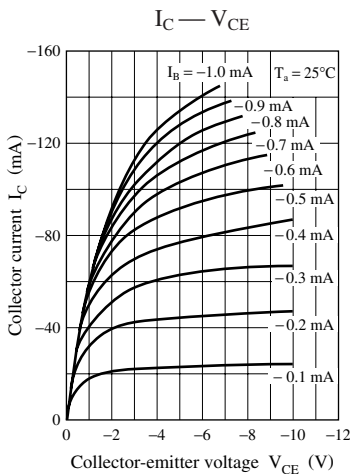

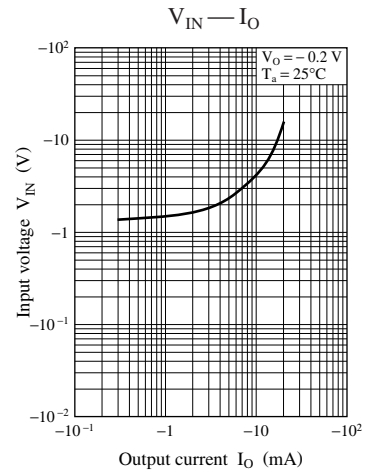
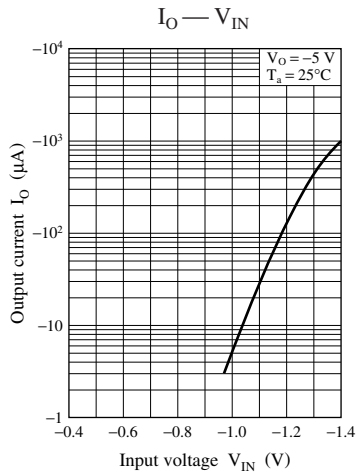
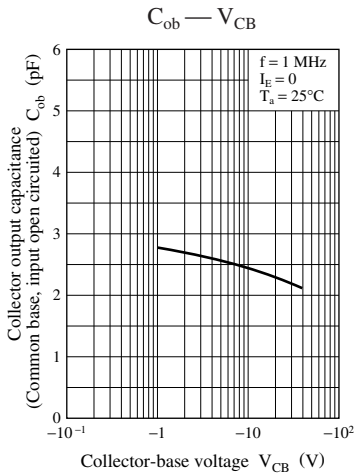

Characteristics charts of UNR9114G

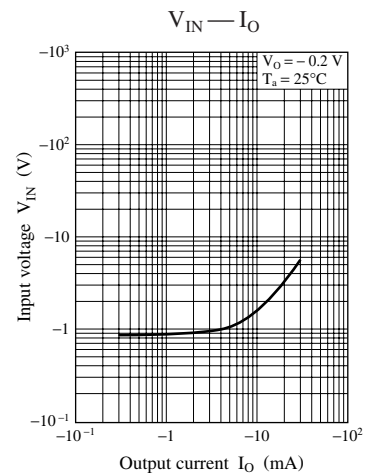
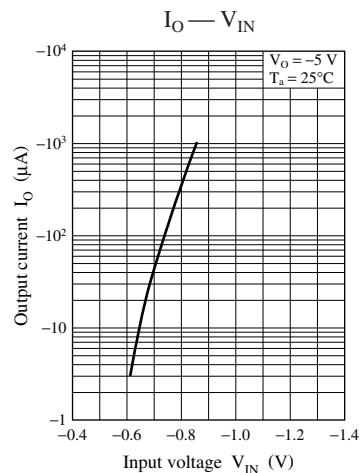
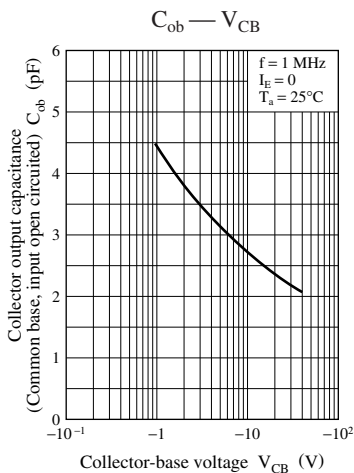
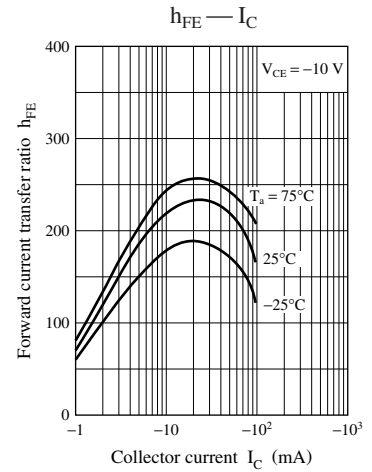
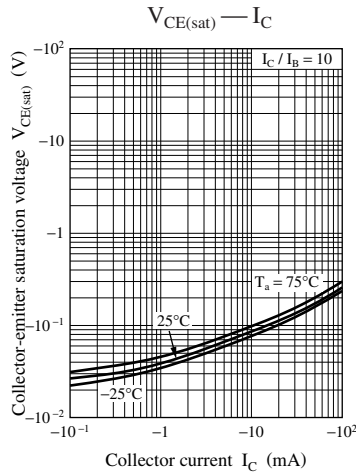
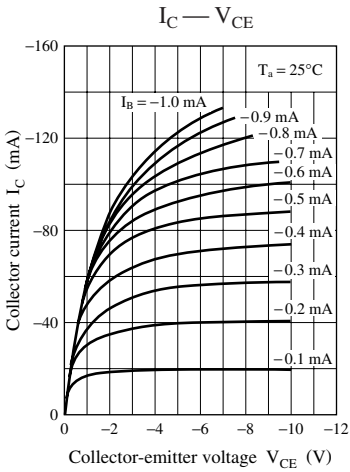

Characteristics charts of UNR9115G

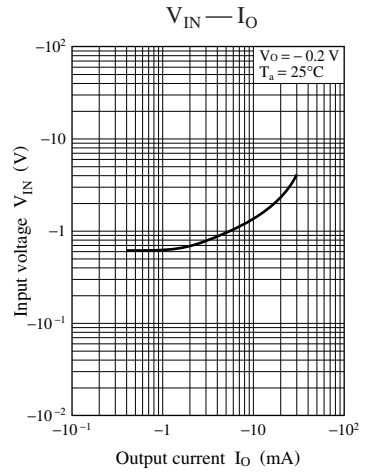
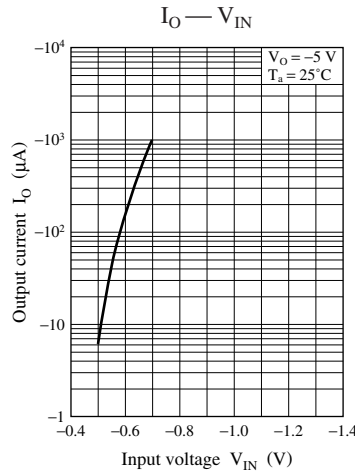
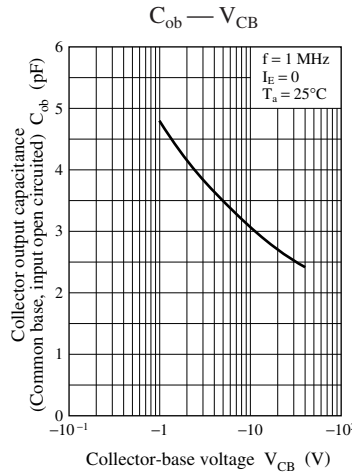
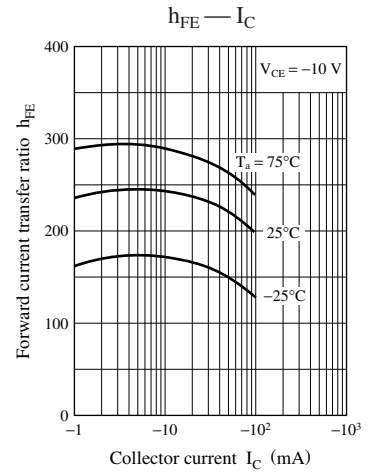
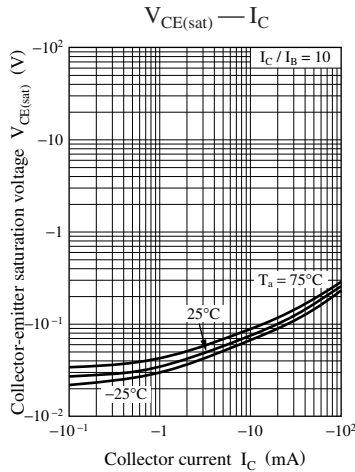
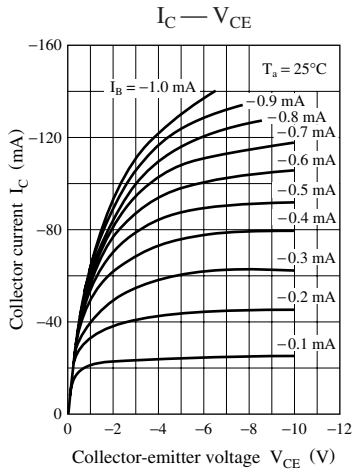

Characteristics charts of UNR9116G

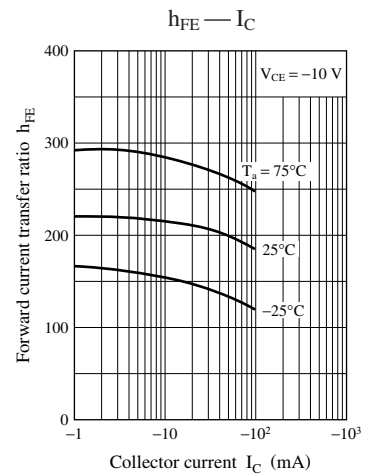
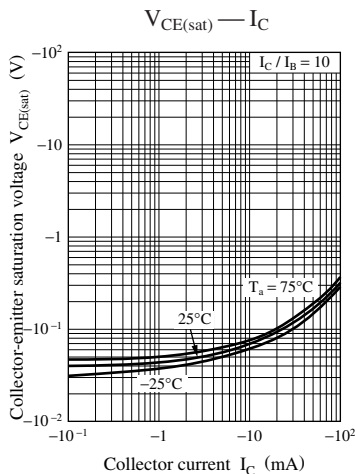
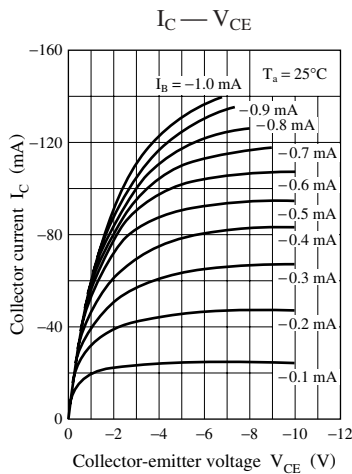

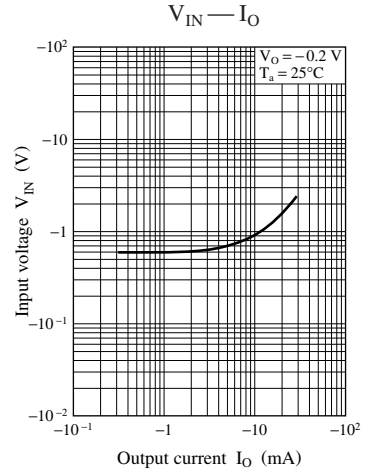
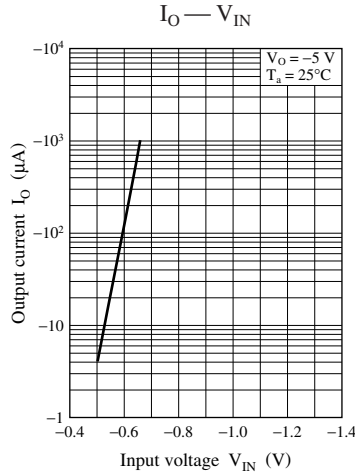
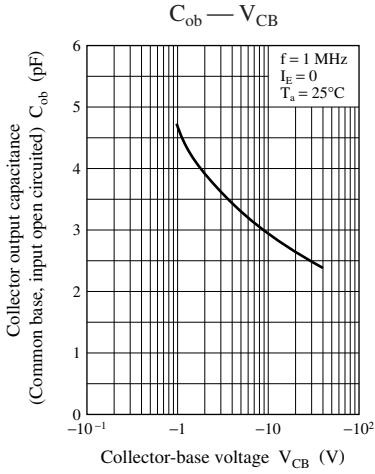

Characteristics charts of UNR9117G

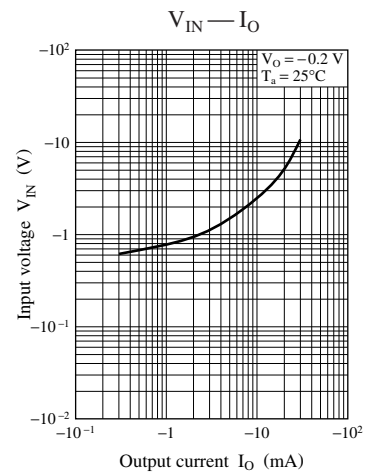
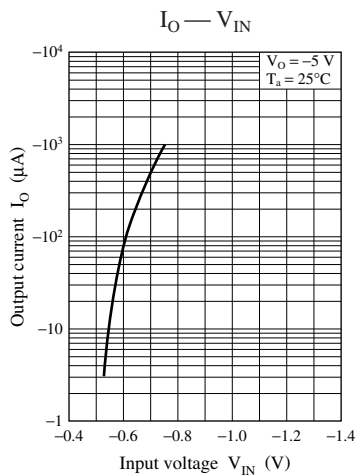
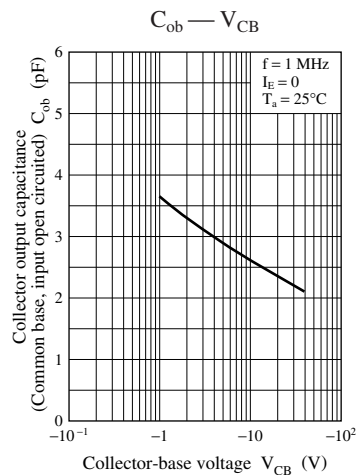
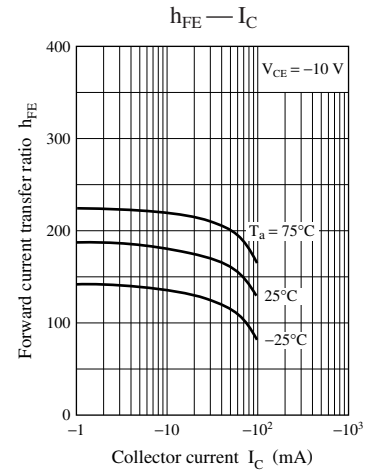
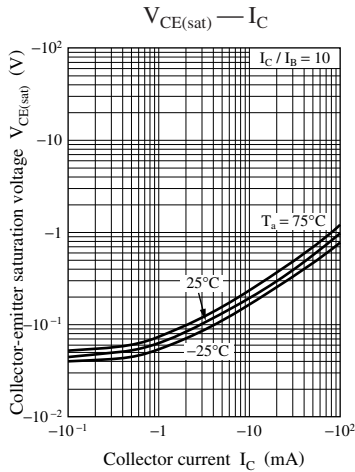
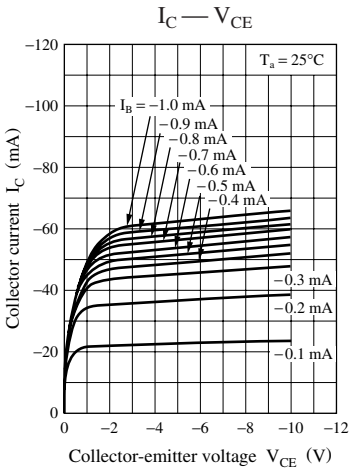

Characteristics charts of UNR9118G

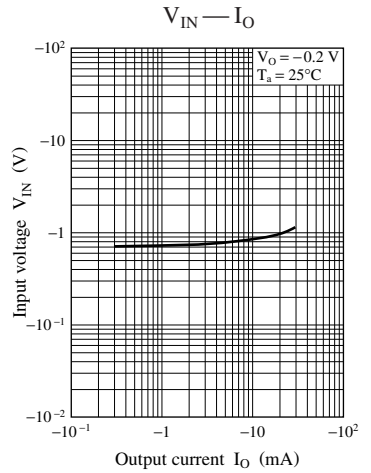
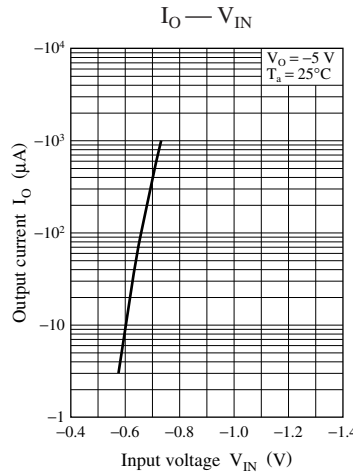
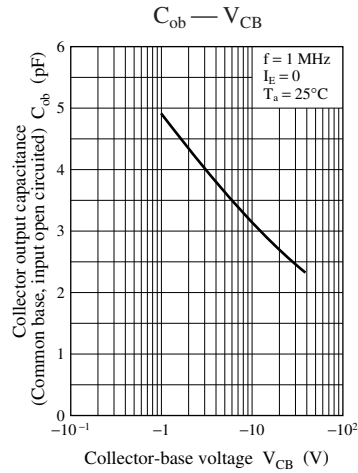
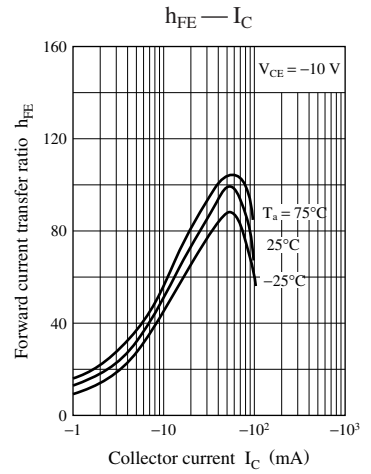
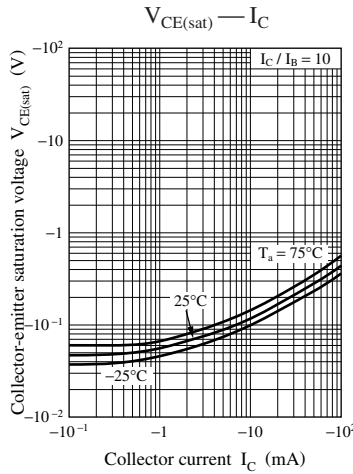
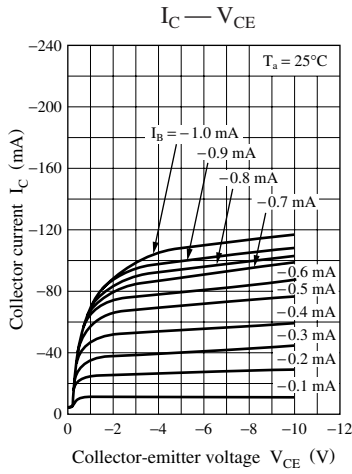

Characteristics charts of UNR9119G

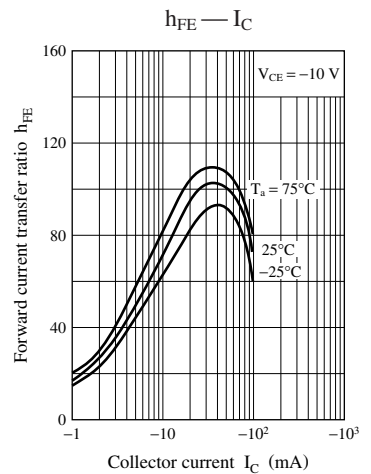
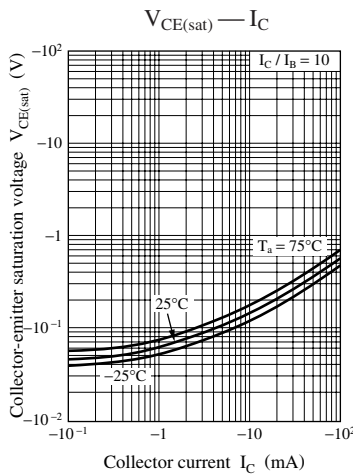
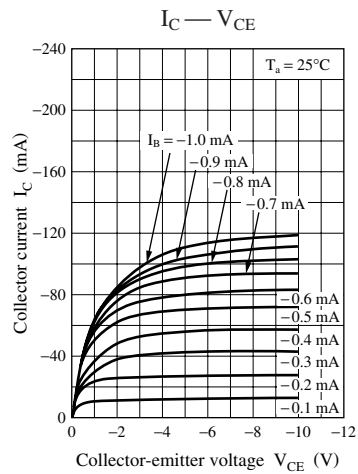

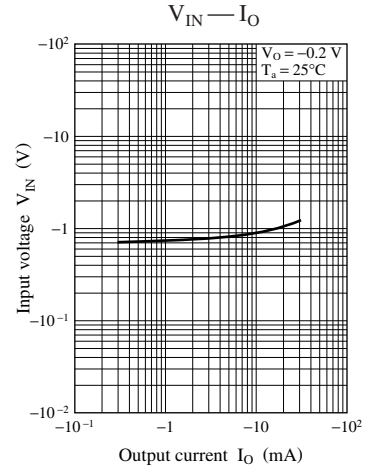
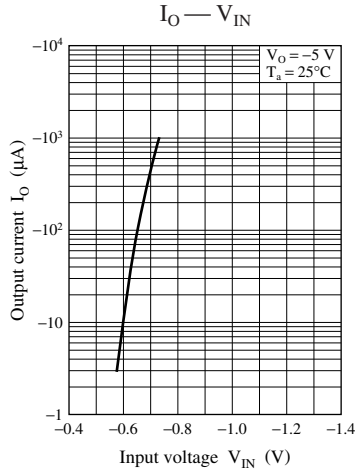
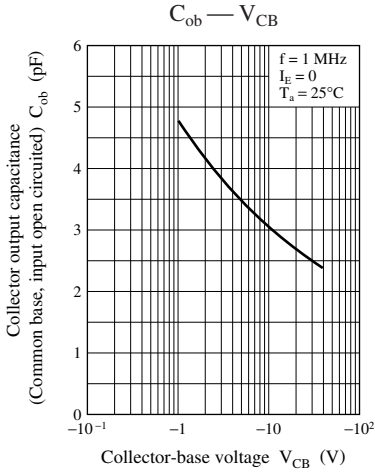

Characteristics charts of UNR911AG

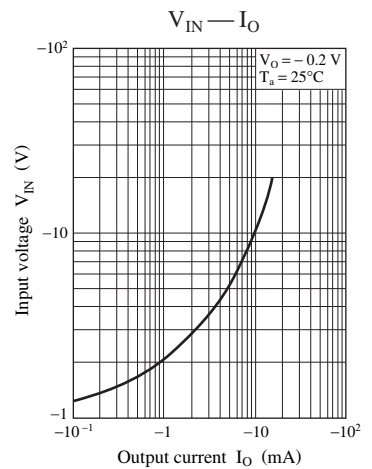
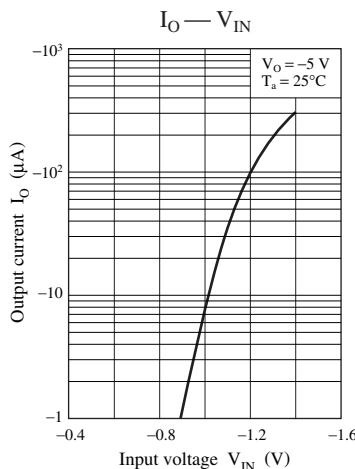
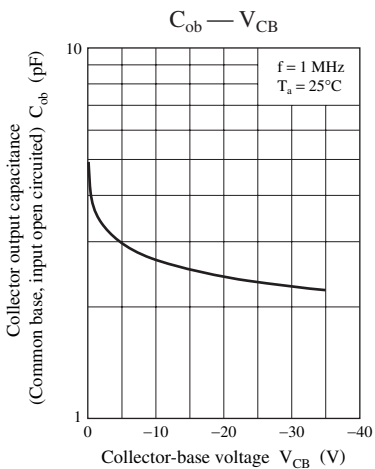
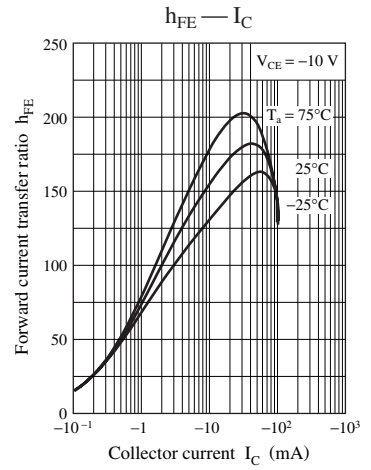
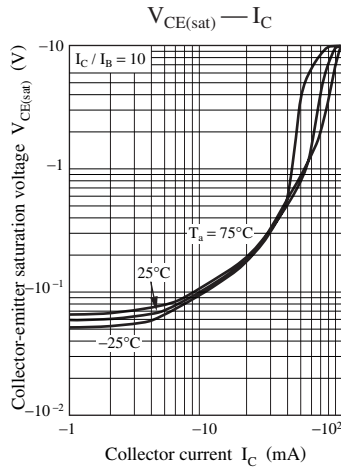
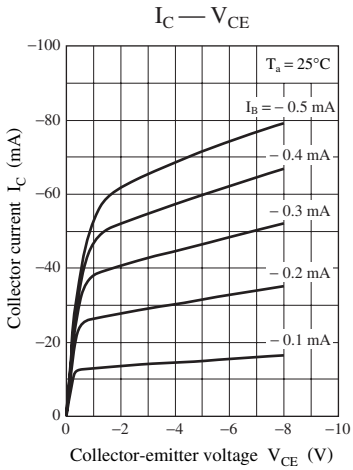

Characteristics charts of UNR911BG

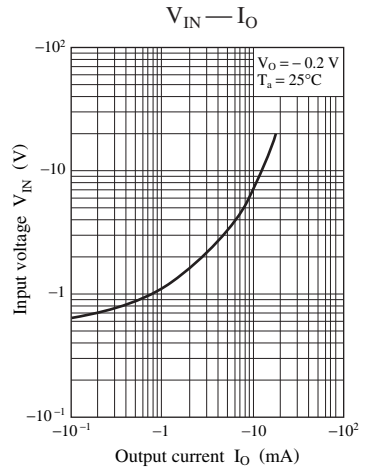
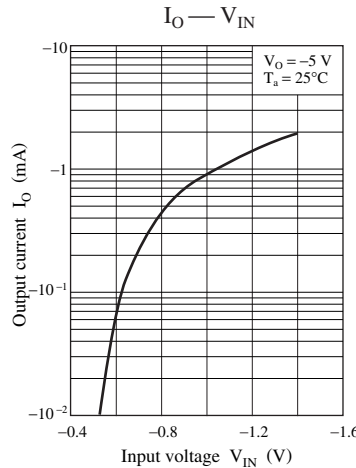
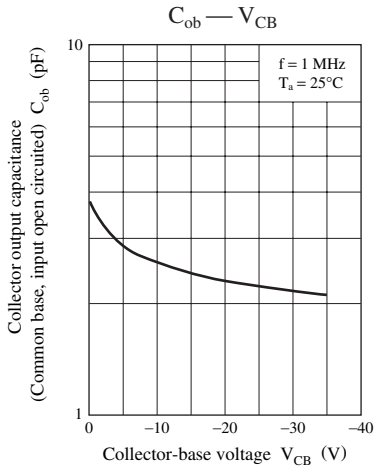
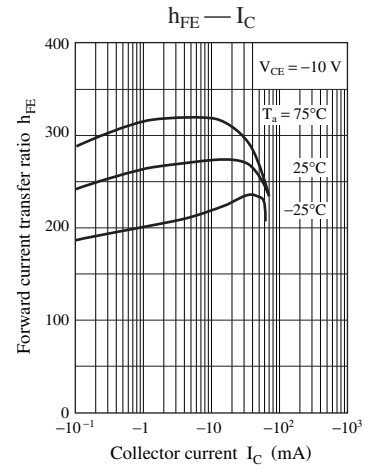
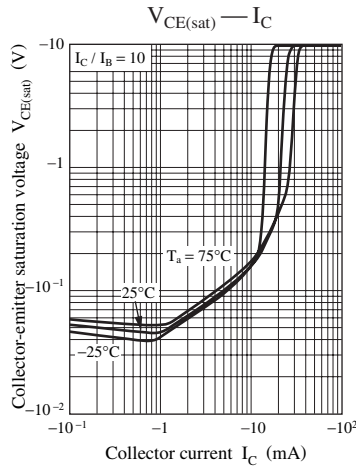
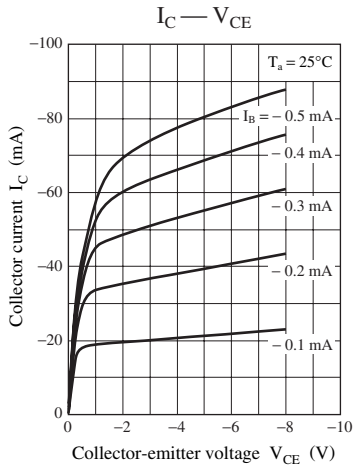

Characteristics charts of UNR911CG

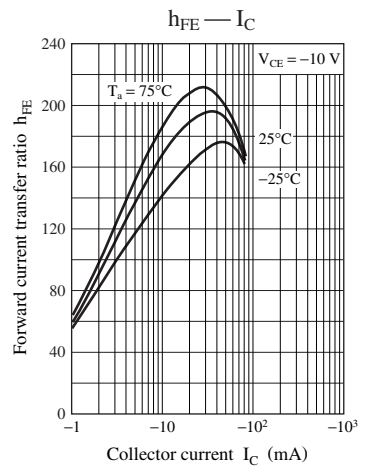
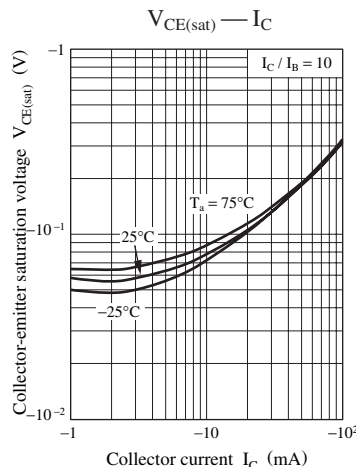
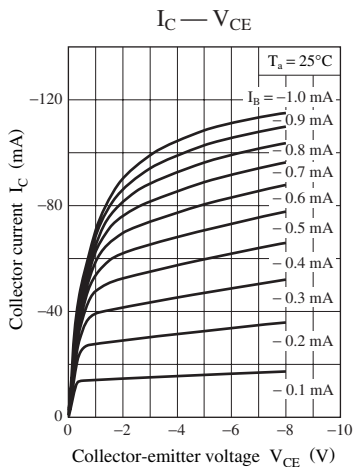

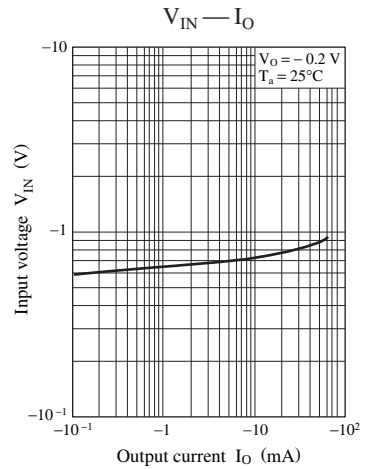
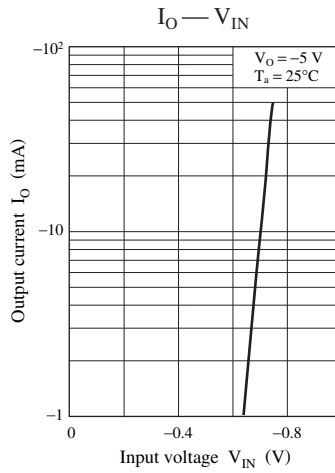
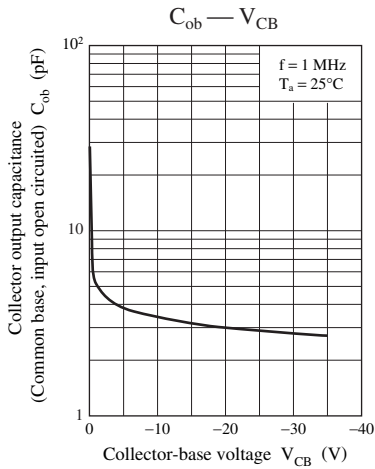

Characteristics charts of UNR911DG

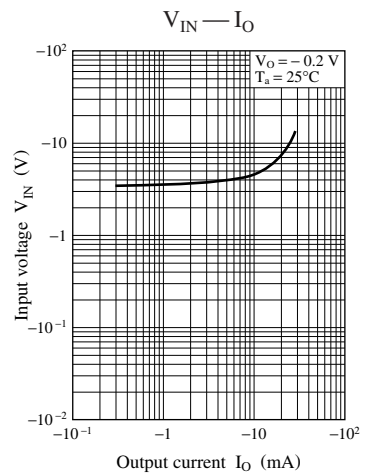
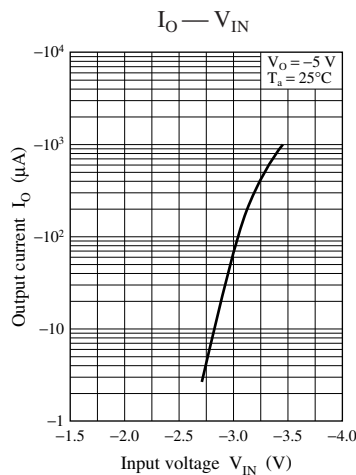
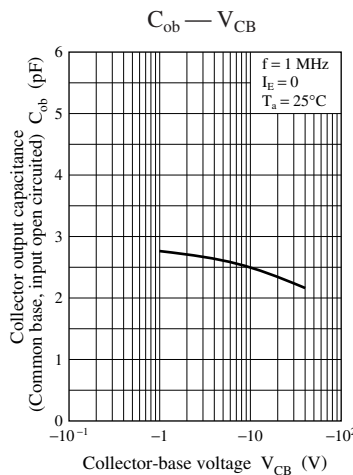
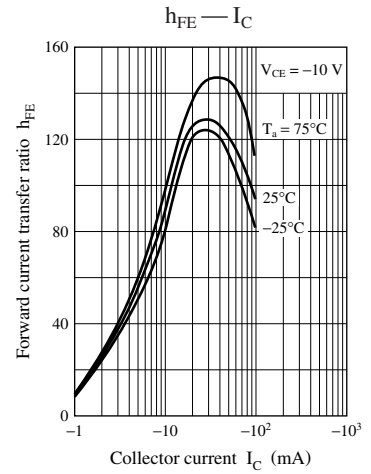
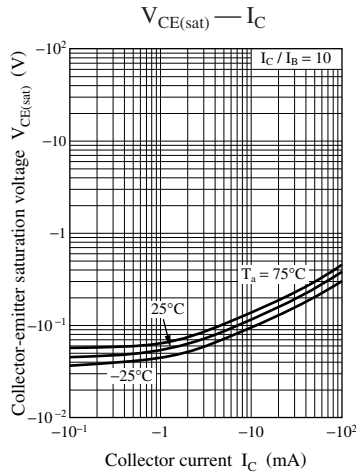
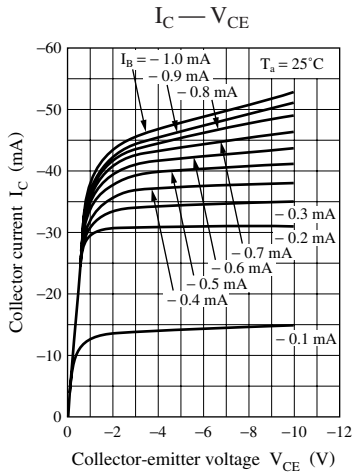

Characteristics charts of UNR911EG

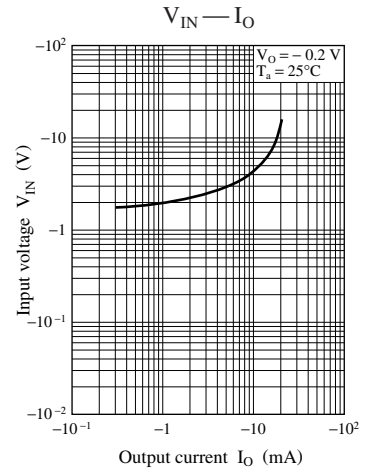
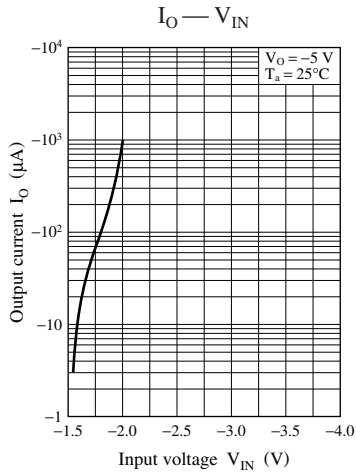
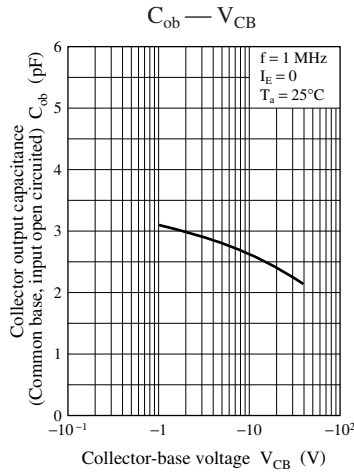
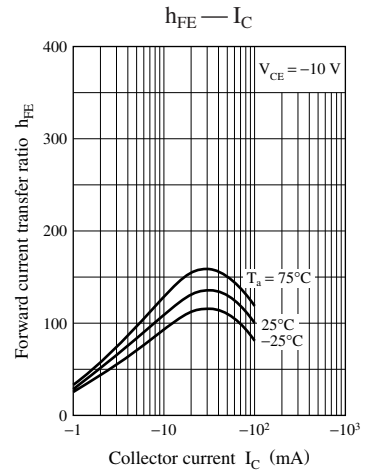
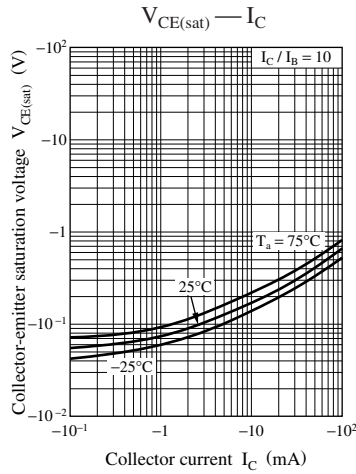
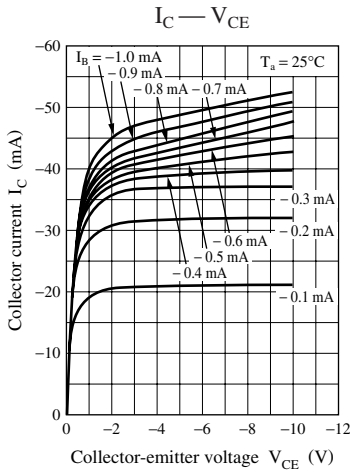

Characteristics charts of UNR911FG

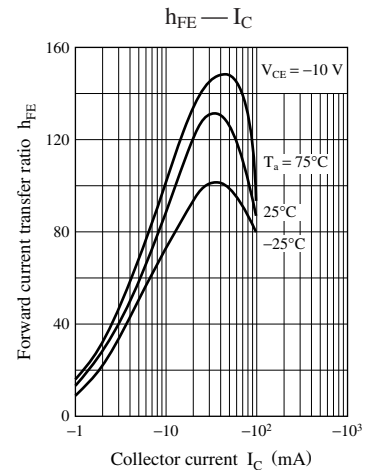
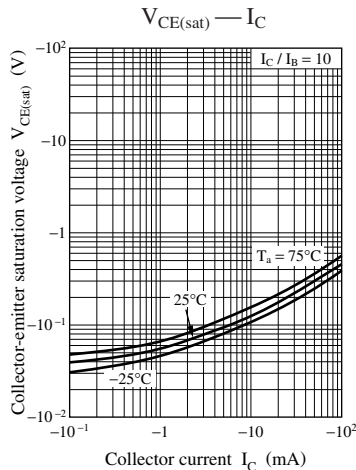
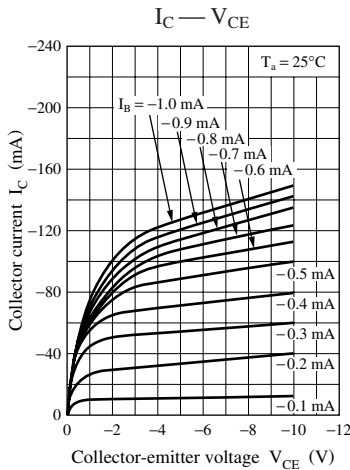

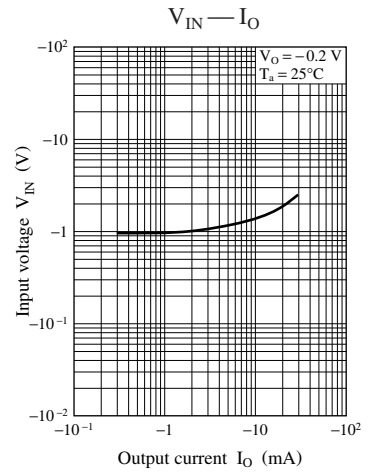
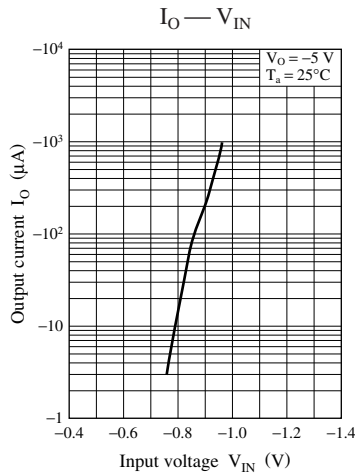
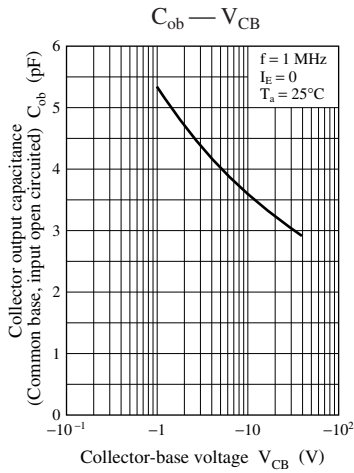

Characteristics charts of UNR911HG

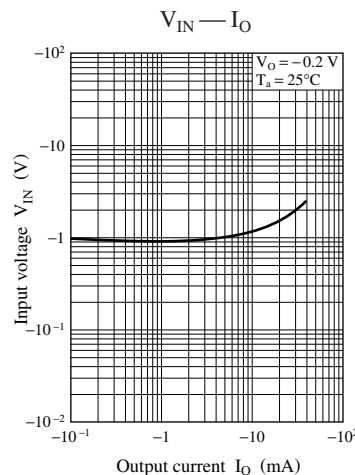
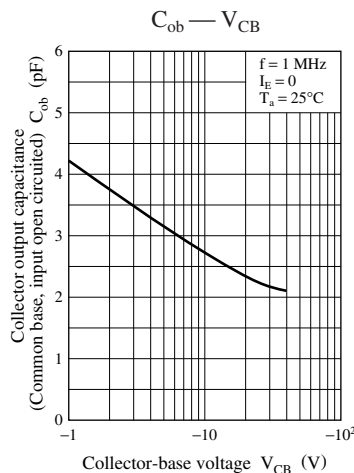
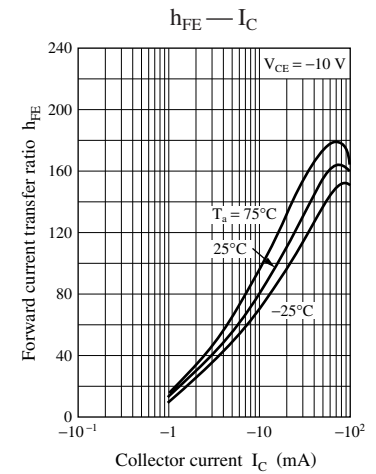
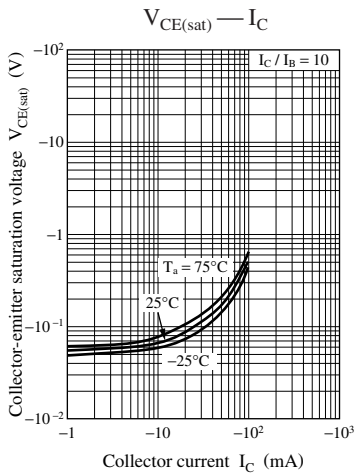
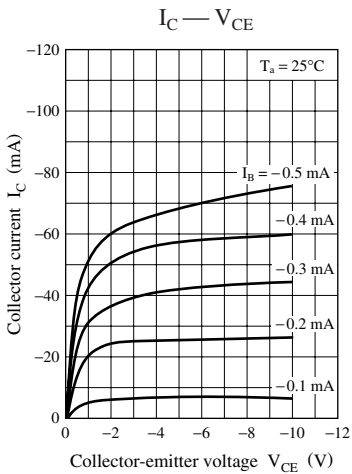

Characteristics charts of UNR911LG

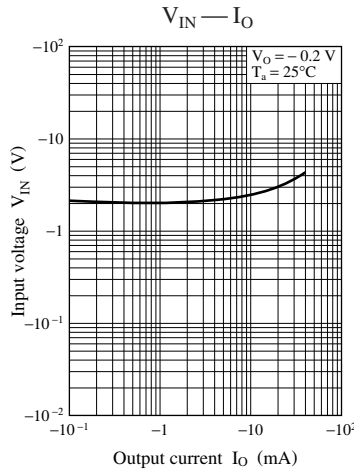
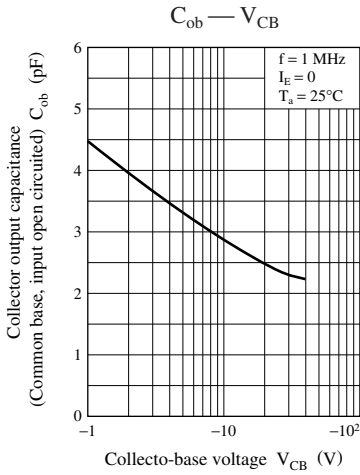
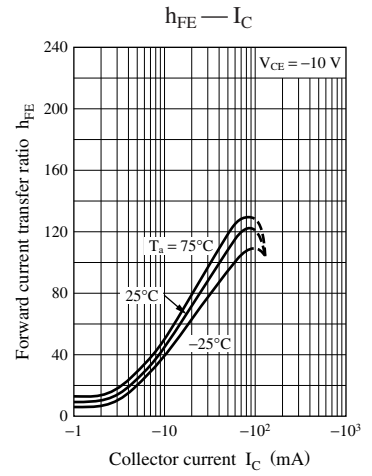
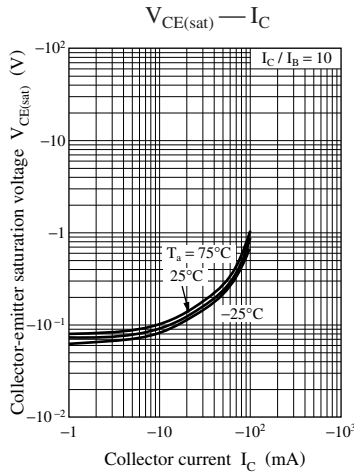
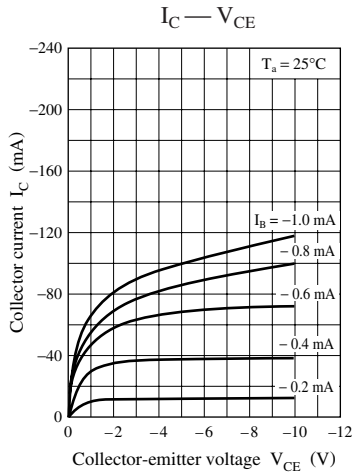

Characteristics charts of UNR911MG

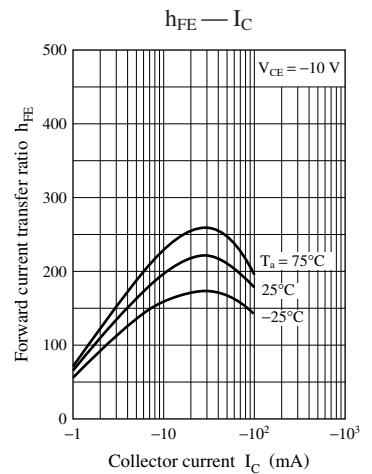
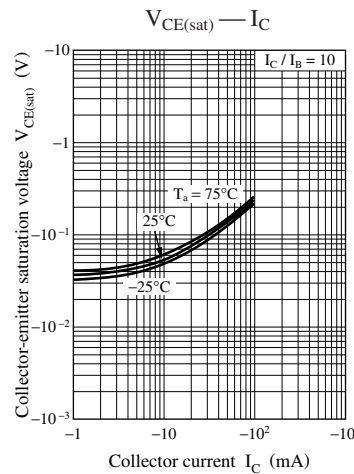
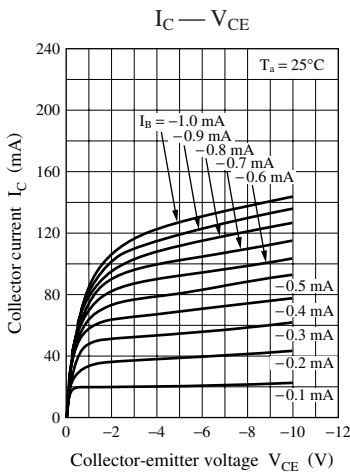

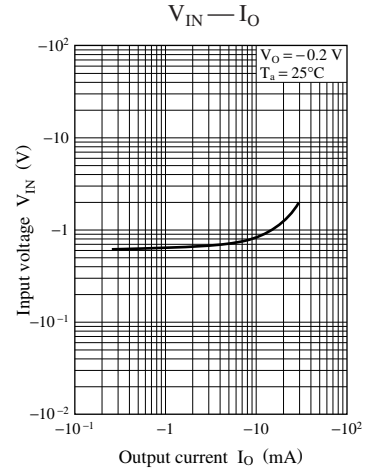
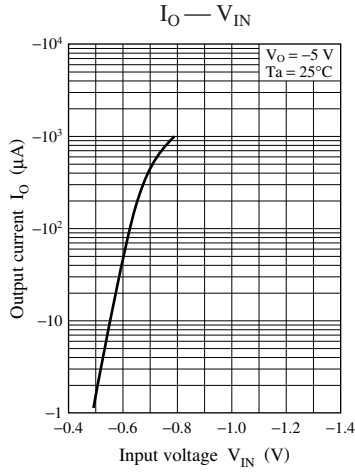
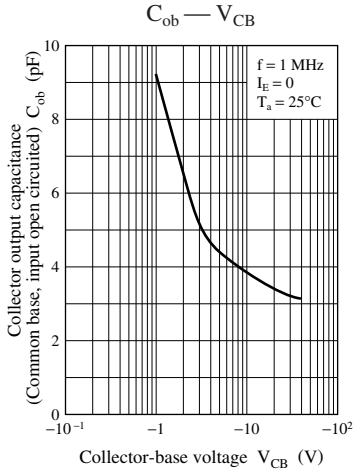

Characteristics charts of UNR911NG

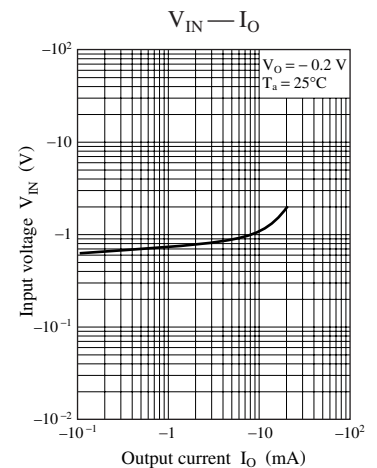
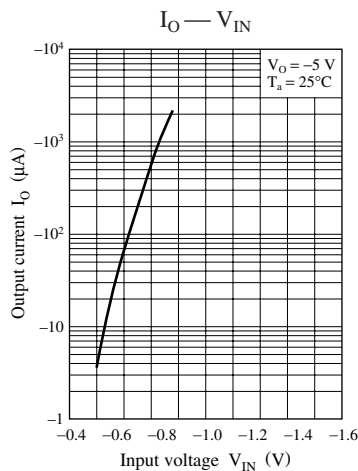
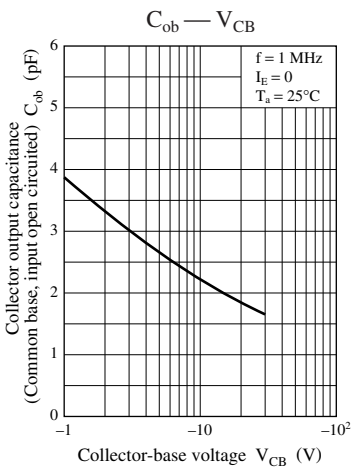
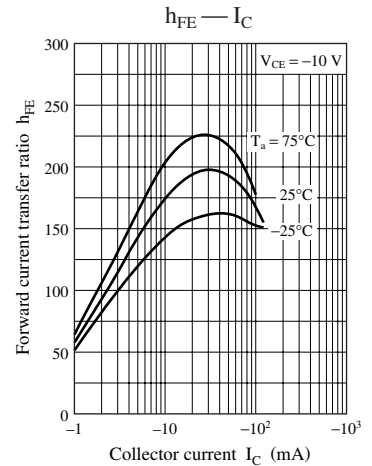
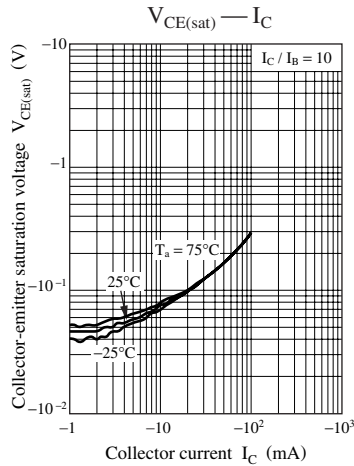
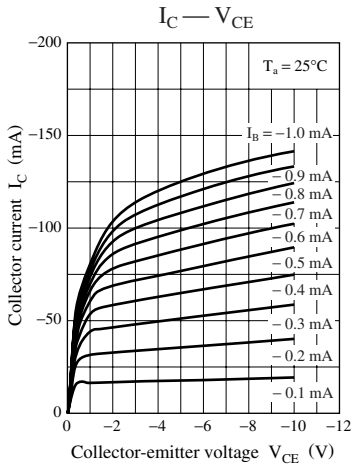

Characteristics charts of UNR911TG

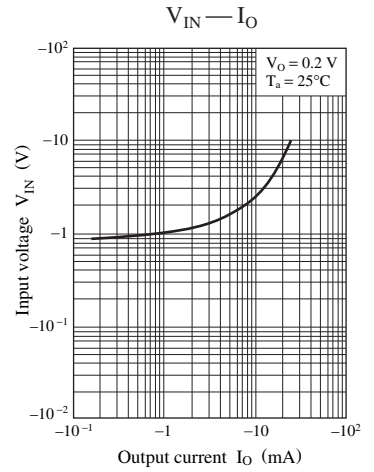
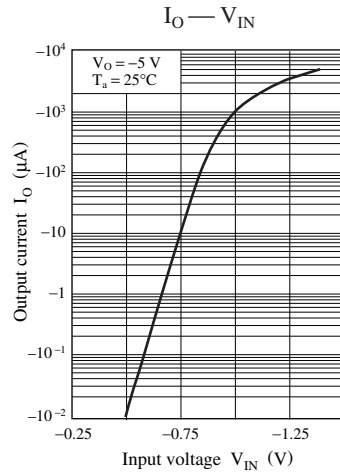
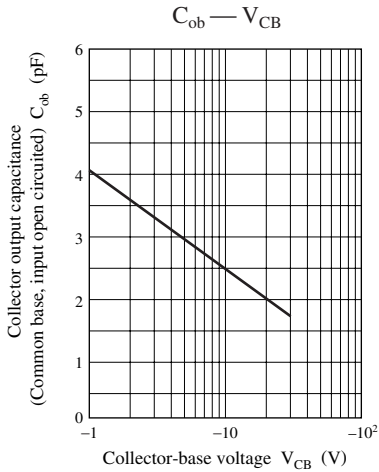
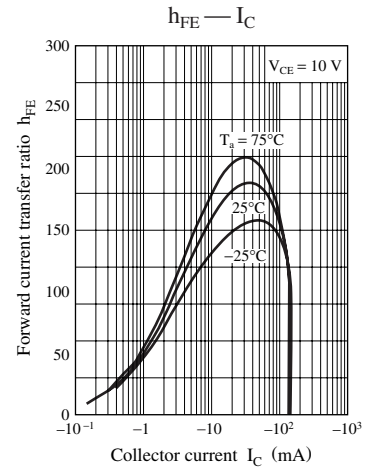
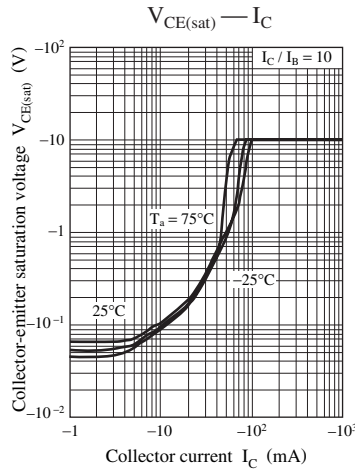
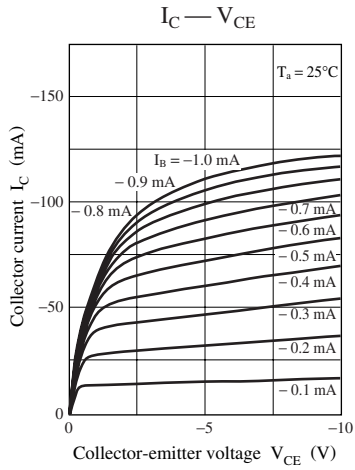

Characteristics charts of UNR911VG

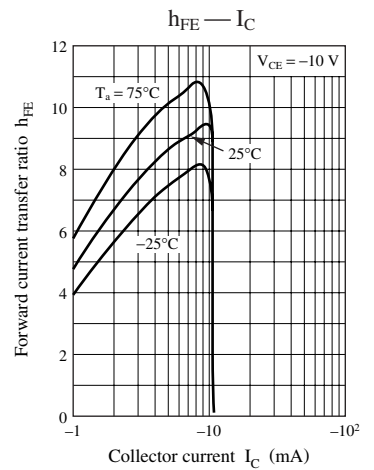
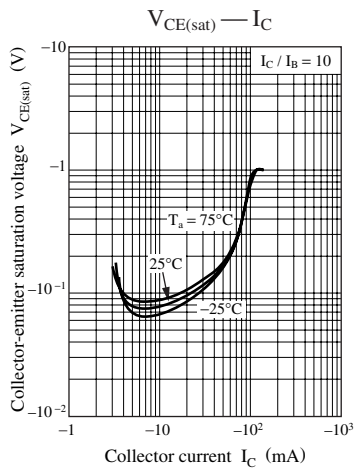
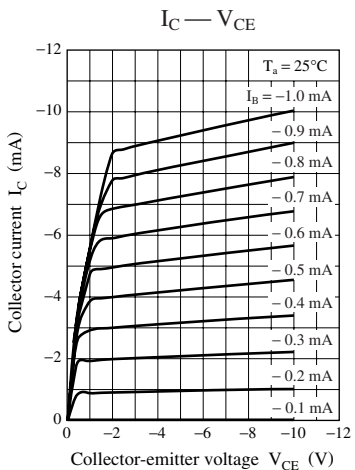

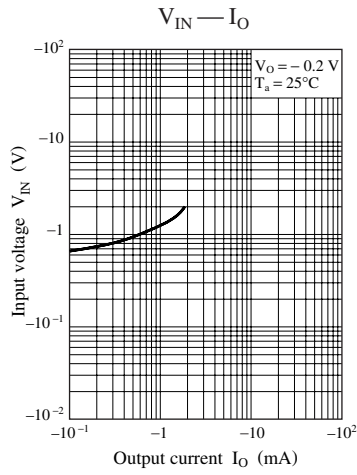
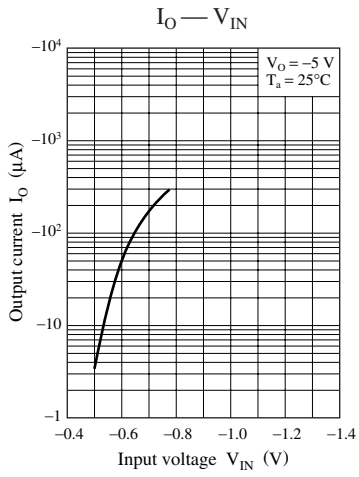

SSMini3-F3

Unit: mm

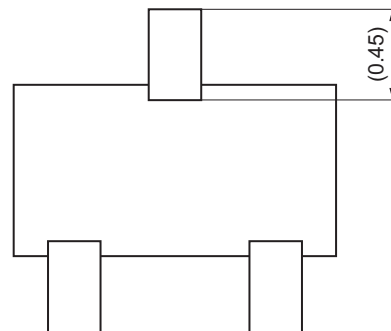
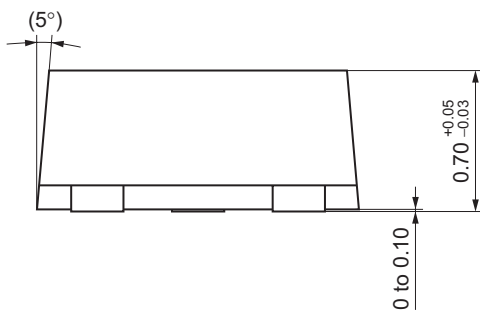
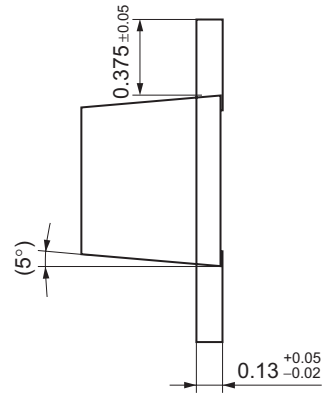
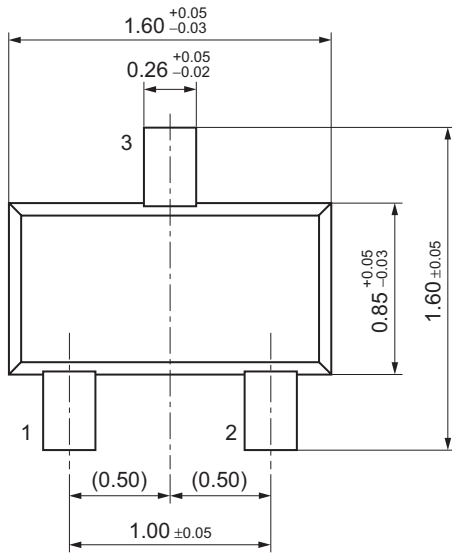

Request for your special attention and precautions in using the technical information and semiconductors described in this book

- (1) If any of the products or technical information described in this book is to be exported or provided to non-residents, the laws and regulations of the exporting country, especially, those with regard to security export control, must be observed.
- (2) The technical information described in this book is intended only to show the main characteristics and application circuit examples of the products, and no license is granted under any intellectual property right or other right owned by our company or any other company. Therefore, no responsibility is assumed by our company as to the infringement upon any such right owned by any other company which may arise as a result of the use of technical information described in this book.
- (3) The products described in this book are intended to be used for standard applications or general electronic equipment (such as office equipment, communications equipment, measuring instruments and household appliances).
Consult our sales staff in advance for information on the following applications:
 - Special applications (such as for airplanes, aerospace, automobiles, traffic control equipment, combustion equipment, life support systems and safety devices) in which exceptional quality and reliability are required, or if the failure or malfunction of the products may directly jeopardize life or harm the human body.
 - Any applications other than the standard applications intended.
- (4) The products and product specifications described in this book are subject to change without notice for modification and/or improvement. At the final stage of your design, purchasing, or use of the products, therefore, ask for the most up-to-date Product Standards in advance to make sure that the latest specifications satisfy your requirements.
- (5) When designing your equipment, comply with the range of absolute maximum rating and the guaranteed operating conditions (operating power supply voltage and operating environment etc.). Especially, please be careful not to exceed the range of absolute maximum rating on the transient state, such as power-on, power-off and mode-switching. Otherwise, we will not be liable for any defect which may arise later in your equipment.
 - Even when the products are used within the guaranteed values, take into the consideration of incidence of break down and failure mode, possible to occur to semiconductor products. Measures on the systems such as redundant design, arresting the spread of fire or preventing glitch are recommended in order to prevent physical injury, fire, social damages, for example, by using the products.
- (6) Comply with the instructions for use in order to prevent breakdown and characteristics change due to external factors (ESD, EOS, thermal stress and mechanical stress) at the time of handling, mounting or at customer's process. When using products for which damp-proof packing is required, satisfy the conditions, such as shelf life and the elapsed time since first opening the packages.
- (7) This book may be not reprinted or reproduced whether wholly or partially, without the prior written permission of Matsushita Electric Industrial Co., Ltd.